

Instructions for Assembling and Disassembling Sleeves under Self-aligning Bearings with Tapered Bore



Video 14: DISASSEMBLING of WITHDRAWAL SLEEVE under self-aligning BEARING (BALL or ROLLER) with HOOK SPANNER

See the step-by-step procedure at www.bgl.com.br/en/treinamento.htm
Technical Videos - **Video 14**

Contents:

Initial preparation before disassembling	03
Disassembling Procedures	04

INITIAL PREPARATION BEFORE DISASSEMBLING

01

Organize the workplace.



02

Select the tools that will be used for the disassembling procedure.



▶ **Disassembling Procedures**

03

Raise the jut of the MB Lockwasher with the help of Screwdriver, pricker and impact hammer.

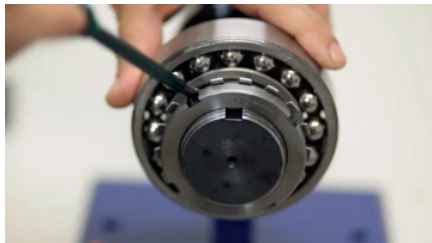

04

Next, loosen the shaft Nut, using an HN Hook Spanner.



05

Remove manually the set Nut-Washer.



06

Use a Nut specific for the Withdrawal Sleeve and the HN Hook Washer.



07

Screw the Nut to the Withdrawal Sleeve, against the bearing, using the Hook Spanner until the bearing comes out.

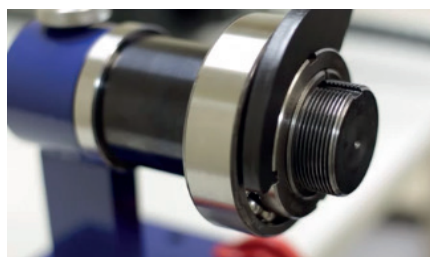

08

And remove the Nut and the Sleeve.

Note: It may happen that the Withdrawal Sleeve be removed together with the Nut.



Atenção: Nunca reutilize uma bucha usada



Eventualmente a bucha de desmontagem será retirada juntamente com a porca.

09

And, finally, remove the bearing.

Note: Used sleeves should not be reused.



To assemble, see **Videos 06** and **08** at www.bgl.com.br/treinamento.htm

TR TRAINING KIT

Practical and dynamic training which helps salespeople and technical staff in their learning.

With the TR KIT you can take your training where you want and as many times as you want.



TR-BGL Kit product available for sale. Consult your distributor.

For more information, see:

Complete Electronic Catalog:
www.bgl.com.br/en/catalogo

Assembling Instructions:
www.bgl.com.br/en/treinamento.htm

Online Reduction Calculation:
www.bgl.com.br/en/calculo_reducao

Catalog Download:
www.bgl.com.br/en/catalogos-folders.htm

Reference Technical Standards:
ABNT NBR 16535-1: SLEEVES FOR BEARINGS
ABNT NBR 16535-2: LOCKNUTS AND LOCKWASHERS

BGL
BERTOLOTO & GROTTA

Sleeve for Bearings
ISO 9001 | since 1957

BGL - Bertoloto & Grotta Ltda
Av. Major José Levy Sobrinho, 1296
CEP 13486-190 | Limeira – SP | Brasil
Phone +55 19 3451-8510
info@bgl.com.br
facebook.com/bglbuchas
www.bgl.com.br